



DaVinci Shake

Select Shake

INSTALLATION GUIDE

DaVinci polymer shakes are carefully engineered to provide the authentic look of hand-split shakes with dramatically increased durability and resistance to fire and impact. Special care has been taken to make the product easy to install. By following these instructions, and using good installation practices, you will be assured a quality installation.

NOTE TO INSTALLER

DaVinci Select Shake offers a 5/8" thick profile, yet remains lightweight, because the shakes have an engineered rib structure. When cutting shakes for valleys or at overhangs such as eaves and gable ends, the ribbed support structure on the underside of the shake needs to be hidden by standard metal flashings.

Pay special attention to recommendations for accessories and installation at eaves (page 2), gable ends (page 4) and valleys (page 6).

JOB SITE READY!

DaVinci shake bundles are delivered to the construction site pre-collated with shingle widths and color variations in the ordered blend. This pre-planned distribution produces the right aesthetic effect every time. Collated bundles also simplify installation and save time by eliminating hand sorting on the job site.



This information is provided for the use of professional roofing contractors. This Installation Guide does not supersede local building codes which should always be followed. DaVinci® Roofscapes does not warranty or have any responsibility for installation of its products. The DaVinci Roofscapes Lifetime Limited Material Warranty outlines its warranty responsibilities for the roofing materials it manufactures.

For questions about DaVinci Shake or its application, contact Westlake DaVinci Roofscapes, LLC
913-599-0766 or 800-DaVinci (800-328-4624) or www.davinciroofscapes.com
Please be sure to check DaVinci's website for updates. Installation Guide is subject to change without notice.

INSTALLATION

DECKING

DaVinci Shake must be installed on a smooth flat surface (plywood or OSB); minimum 15/32" APA approved plywood or 7/16" approved OSB. It is necessary that all previous roofing materials be removed prior to installation of DaVinci Shake. Imperfections in the decking may transmit through to finished roof.

Prior to installation over any plank type decking please see the [technical bulletin](#), RE: DaVinci & Installation Over Plank Decking, dated October 24, 2022 for possible concerns or warranty exclusions.

DRIP-EDGE

Metal flashing is required on gable ends and eaves. An overhanging drip edge is recommended on gable ends to help mask the rib structure on the underside. An overhanging drip edge may also be used on eaves although non-overhanging drip edge styles are acceptable options.

SELF-ADHERED MEMBRANE

(Severe Climate Underlayment in accordance with Chapter 15 of the UBC)

In areas where the average daily temperature in January is 25° F or lower or where ice buildup is possible, DaVinci requires self-adhered membrane be installed: from the bottom edge extending two feet above the exterior wall line on all eaves. The self-adhered membrane is required in all valleys regardless of average daily temperatures or the possibility of ice buildup.

UNDERLAYMENT AND INTERLAYMENT (See Davinci Document Library for possible additional options)

Typical Unrated Installations: Minimum underlayment options are One layer of ASTM D226 Type II (30 lb) Asphalt-saturated organic felt, or, One layer of synthetic underlayment approved as an alternate to ASTM D226 felt, or, One layer of self-adhered membrane covering entire roof deck.

Rated Installations:

Method 1: Class A installation

One layer of GAF VersaShield® Fire-Resistant Roof Deck Protection (ESR-2053) in addition to required self-adhered membrane.

Method 2: Class A Installation

One layer Fontana VulcaSeal G40 in addition to the required self-adhered membrane(This system is not recognized by ICC-ES).

Method 3: Class A Installation

One layer of Eco Chief SOLARHIDE (ESR-4035) in addition to the required self-adhered membrane.

Method 4: Class C Installation

The entire roof must be covered with an approved underlayment in addition required self-adhered membrane.

Pitches below 6:12

Felt Interlay/Alternative Options – Felt interlay may be added to any Davinci Shake install for additional protection from weather and is one of the options to cover additional requirements with certain installations. DaVinci Shake must be installed with 30 lb. felt interlay or an appropriate option if the pitch of the roof is under a 6/12 and an exposure beyond 9" (for example 10" straight or 9" staggered)is desired. An alternative to using felt interlay is to use two layers of an approved underlayment with their laps offset. (Felt interlay is installed by rolling out 18" wide rolls of 30 lb felt at the same exposure as the shakes. The felt should be applied over the top portion of the shakes and extend onto the plywood sheathing so that the bottom edge of the felt is positioned at a distance above the butt equal to twice the weather exposure. So for an exposure of 10", start the layer of felt 20" above the butt line of the course below).

Class A Installation

- **Felt Interlay** - must be used in addition to one of the other Class A approved underlayments listed above.
- **Two layer option** - An alternative to using felt interlay is to use two layers of approved underlayment with their laps offset. One of these layers must be Eco Chief SOLARHIDE (ESR-4035),GAF VersaShield, or Fontana VulcaSeal G40.

Note 1: Approved underlayment refers to any underlayment that is listed as a component of a Class A roof deck assembly by an Approved Agency when tested to ASTM E108 or UL 790.

Note 2: Underlayment and Asphalt Shingle components are to be installed with mechanical fasteners in accordance with the manufacturer's published installation instructions. Self-adhering or adhesive applied underlayment and asphalt shingle installations are outside the scope of this listing.

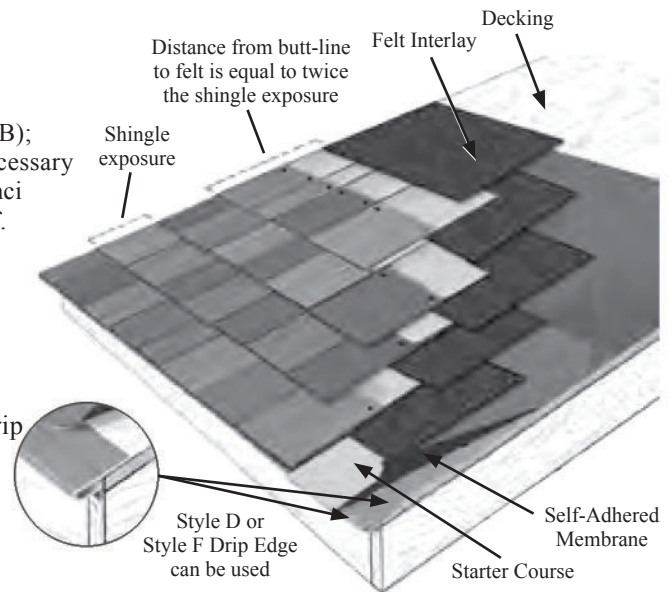

INSTALLATION

FASTENERS

Tiles should be installed with nails long enough that they will penetrate through the roof deck by at least 3/16". In most instances, 1 3/4" roofing nails are acceptable. We recommend copper, stainless steel, or hot-dipped galvanized nails. Ring-shank nails are optional for plywood, but must be used for OSB decks and in high wind areas.

STARTER COURSE

Each starter tile should be installed so that it extends past the drip edge by approximately 1". If using overhanging drip edge, the starter shingle may overhang less if it is appropriate for the gutter system. The starter tiles should be installed with the DaVinci logo on top. The starter tiles should be spaced 3/8" apart as tiles will expand when warm. Each starter tile should be nailed with two approved nails on a line approximately 6" from the butt and 3/4" from outside edge.

GETTING STARTED

Use approved nails in each shake at or near nailing location shown on the shakes (see page 8). Nails may be placed lower than the indicators as long as the tile above it covers the nail. Once the starter tiles are in place, begin installing shakes in the lower left corner (or lower right corner for a left-handed roofer). The shakes should be flush with the starter tiles on the outer (rakes) and lower (eaves) edges. DaVinci recommends a minimum 3/8" gap between shakes.

Two methods of installation are available:

1. Straight: in which the exposure of each shake is kept consistent
2. Staggered: in which the exposure varies by a maximum of 1" on adjacent shakes

Use the alignment indicator at the top of each shake to help manage the exposure. An exposure of between 9" or 10" is acceptable for straight courses and 9" for staggered courses. As you progress up the roof, be careful not to damage shakes already in place. Put something, perhaps a piece of cardboard or cut shake, under toe irons (scaffolding brackets) to avoid scratching or marring the shake already installed below.

STRAIGHT COURSING

Install the shakes one at a time starting in the lower left hand corner if right handed or lower right hand corner if left handed. The first course of shakes should be laid directly on the starter tiles with the butt of the shake flush with the butt of the starter tile. The shakes should be installed individually with two nails in or near the defined areas. The shakes should be laid individually with a rack type system, also known as rack-style, stair-stepping, or pyramiding; to prevent same size shake directly on top of another. The shakes should be laid with an approximate 3/8" gap between each shake. The gaps between shakes on adjacent courses should offset by a minimum 1 1/2". To assure proper horizontal alignment we recommend that chalk lines be snapped frequently. These chalk lines should be placed on the underlayments so that the shakes are aligned by the tips of the tiles rather than the butts.

Chalk lines should be snapped on underlayment with the tips of the shakes following the lines. Do not snap lines on DaVinci Shake or use red chalk as the chalk may permanently discolor the shake.

STAGGERED COURSING

DaVinci Select Shake may be staggered using a similar method as Single-Width and Multi-Width Shake. This will mean that it will appear that two tiles are pulled down at once in some instances. When necessary the tiles with false breaks may be cut in the false break area to create two distinct tiles.

Select Shake tile do not have alignment indicators so the courses should be aligned with a chalk line at the tip of tile or alternately with shake liner.

Staggering the courses is accomplished by laying the shakes in 9" courses with every other shingle lowered 1".

An example of how to accomplish this is as follows:

Straight Coursing on DaVinci Shake at a 10" Exposure

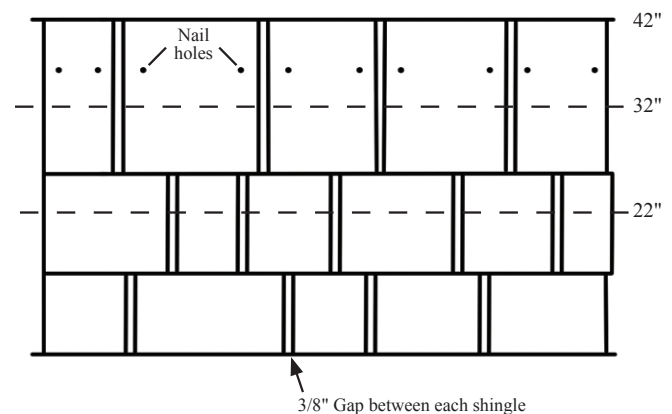

Staggered Coursing on DaVinci Shake at a 9" Exposure

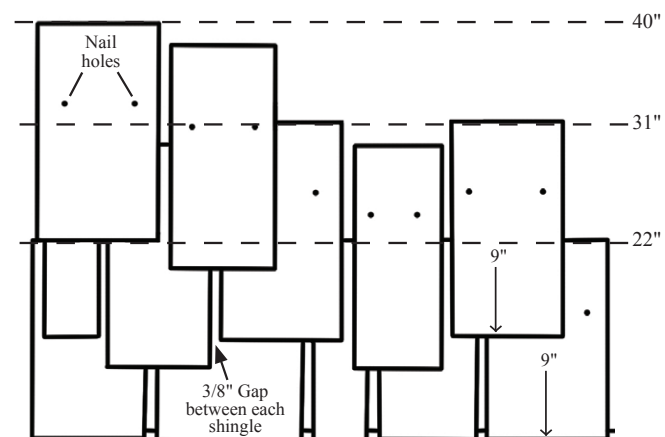

INSTALLATION

STAGGERED COURSING *(Continued)*

Step 1: Lay the first course of shakes flush on top of the starter. Then snap a horizontal line 9" above the tips of the shakes you just installed or 31" from the eave line (butt of the shake you just laid).

Step 2: The first shake on second course should be installed putting the tip of the shake on the chalk line. The next or adjacent shake should be 1" below the line. The third shake should be on the line; the fourth shake should be below the line. This continues in the same pattern all the way across the roof one shingle tip on the line and the next 1" below the line.

Step 3: Snap another horizontal line 9" above the line you chalked in Step 2 or 40" above the butt of the first course of shakes. Start laying shakes as in Step 2 with the first shake tip on the line and the next shake tip about 1" below the line.

Step 4: Continue up the roof in this manner.

Tip: 10" tiles with a false keyway can be cut along the false keyway and used as two individual pieces. This will create a more random look. Cut the keyway with a knife vs. a saw for a cleaner cut.

Chalk lines should be snapped on underlayment with the tips of the shakes following the lines. Do not snap lines on DaVinci Shake or use red chalk as the chalk may permanently discolor the shake.

GAP

The recommended gap between shakes is 3/8" with a minimum 3/16" gap required. The number of shingles per square for DaVinci Shake is based on the assumption of 3/8" spacing between shakes. If spacing is less, more shingles per square will be required.

AVOID "CRACK ON CRACK"

The gap between two shingles in one course should always line up 1/2" or more from the gap between two shingles in the course below. When possible, the same rule should apply to false breaks although this is for aesthetic reasons and will not affect the performance of the roof system.

Correct



Incorrect

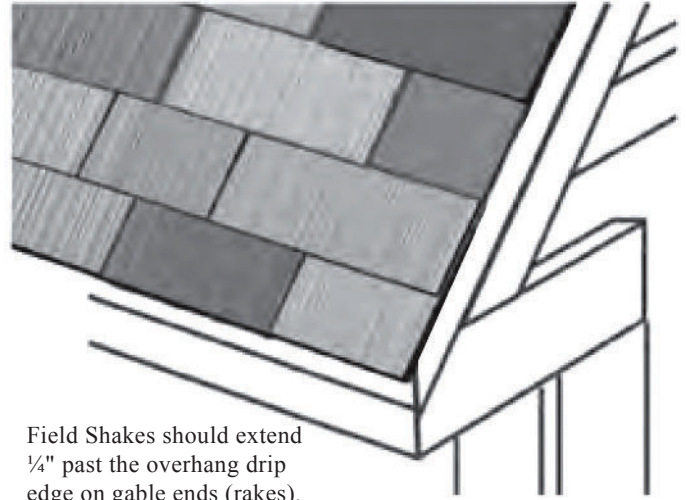

Field Shakes should extend 1/4" past the overhang drip edge on gable ends (rakes).

GABLE ENDS / RAKES

Cutting Select Shakes at gable ends, shakes should be cut so that the factory edge faces out on the gable end. When necessary the tiles with false breaks may be cut in the false break area to create two distinct tiles.

CUTTING

DaVinci Shake may be cut with a utility knife and straight edge. It may also be cut effectively with a circular saw. Carbide tooth blades are recommended for maximum blade life.



COLOR AND WIDTH VARIATION

Davinci Select shake bundles are made up of 8 different shake (tile) shapes. Four of the tiles are 8" wide and four are 10" wide. Of the four 10" tiles, three have false breaks making them appear to be two different shakes and one of them is a 10" tile without a false break. DaVinci Roofscapes recommends that the shakes should generally be installed as they come out of the bundles. Keep in mind there must be 1/2" side lap maintained and installation must be in a rack or pyramid style.

INSTALLATION

ONE-PIECE HIP AND RIDGE APPLICATION: HIP AND RIDGE PREPARATION

Select Shake uses the Shake One-Piece Hip and Ridge. DaVinci one-piece hip and ridge shakes have an optimum appearance when used on pitches of 12:12 or less. Steeper pitches may cause outside edge to lift and it is recommended the conventional two-piece hip and ridge method be used for pitches greater than 12:12. Roofing nails that penetrate through the roof deck and exceed it by 3/16" should be used.

RIDGE VENT APPLICATION

If using a continuous ridge vent we recommend a rigid shingle roll-over type. Once the continuous vent is installed, prepackaged One-Piece Hip and Ridge shingles should be installed in accordance with the standard hip and ridge installation instructions below. Special caution should be used when cutting the decking on the ridge to assure adequate nailing for the ridge pieces.

DAVINCI ONE-PIECE HIP AND RIDGE SHINGLE INSTALLATION

The one piece hip and ridge tile should be installed at a 12" exposure. The tiles should be nailed once on each side about 3/4" from the outside edge with an approved fastener long enough to penetrate through the roof deck and exceed it by 3/16". (2 1/2" roofing nails are acceptable in most instances.) The hip and ridge should be nailed approximately 12 1/2" from the butt of

the tile, and 1/2" to 3/4" inch from the outside edge. When nailing, it is best to try to nail the hip and ridge through the butt of the field tile, not in the void below the butt. The nail may be raised up to an inch above the nailing circle if necessary. If the tile must be nailed in the gap below the butt of the field tile, don't drive the nail down so hard that it distorts the hip and ridge tile. A chalk line should be used on the hips to assure straightness. A shingle over type continuous ridge vent may be used if wanted. If continuous ridge vent is used, nails used to secure the hip and ridge tiles must penetrate through the decking and exceed it by 3/16".

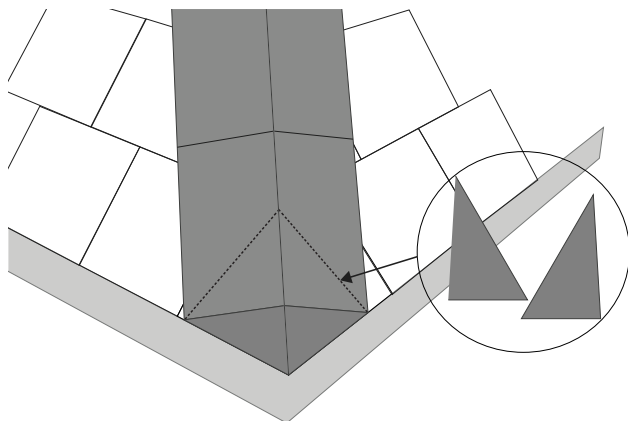
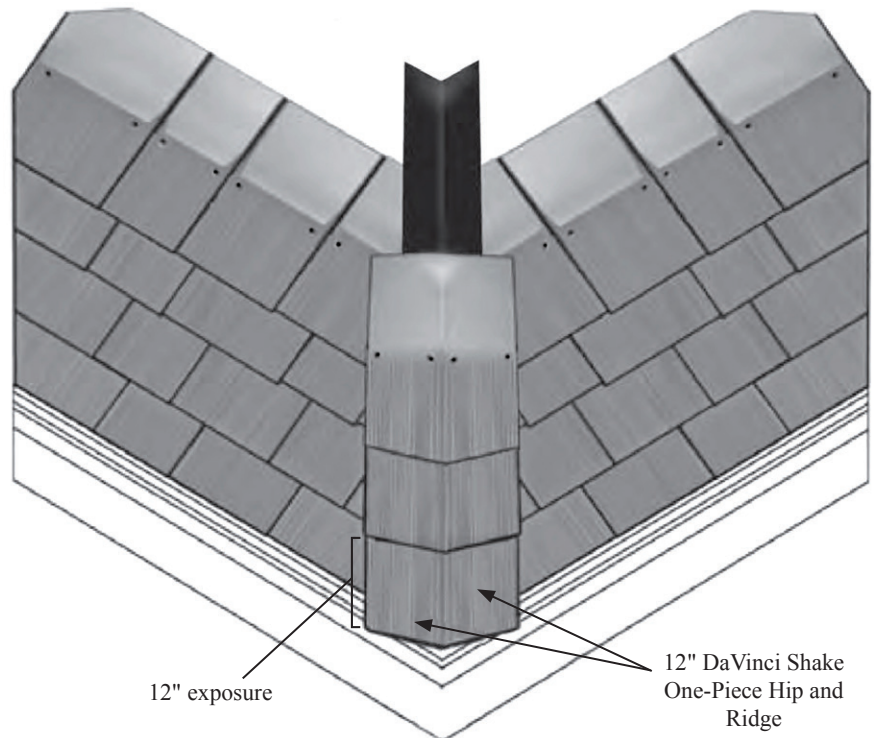

Hip Starter Application:

At the bottom of a hip, the hip and ridge tile may be cut on an angle so that the bottom edge may be installed parallel with the eave. A piece of flashing or UV stable roofing material should be installed along the bottom 6" of the hip in order to protect the area under the seam formed by the cut material. The cut hip and ridge tile is then assembled so that the two cut pieces are butted together to form the bottom piece of hip and ridge. Once these two tiles are in place, a full hip and ridge tile is installed and pulled down so the outside corners just reach the bottom of the roof.

INSTALLATION

TWO-PIECE HIP AND RIDGE APPLICATION: HIP AND RIDGE PREPARATION

After installing field shakes, hips and ridges should be prepared by installing a minimum 6" wide piece of non-corrosive metal, UV stable EPDM or equivalent over the hips and ridges. This metal or EPDM should extend at least three inches from the center point on each side of the hip or ridge.

RIDGE VENT APPLICATION

If using a continuous ridge vent we recommend a rigid shingle roll-over type. When installing continuous ridge vent, care should be taken to insure joints in ridge vent are water tight. Once the continuous vent is installed, prepackaged 6" DaVinci hip and ridge shakes should be installed in accordance with the standard hip and ridge installation instructions below. Caution should be used when cutting the decking on the ridge to assure adequate nailing for the ridge pieces. Roofing nails that penetrate through the roof deck and exceed it by 3/16" should be used.

TWO-PIECE HIP AND RIDGE SHINGLE APPLICATION

The bottom piece of hip and ridge should be cut so the tip does not extend past the butt of the second course. If preferred on the bottom of a hip, two 6" DaVinci Shake cut 5" wide placed upside down can be used as an under course. This will prevent the rib structure from being seen on the underside. These shakes that make up a hip and ridge unit should be installed with a **ten-inch exposure**. Using a chalk line to assure straightness, the prepackaged 6" hip and ridge should be installed one piece at a time so that the butts of two shingles are adjacent and the inside edges touch.

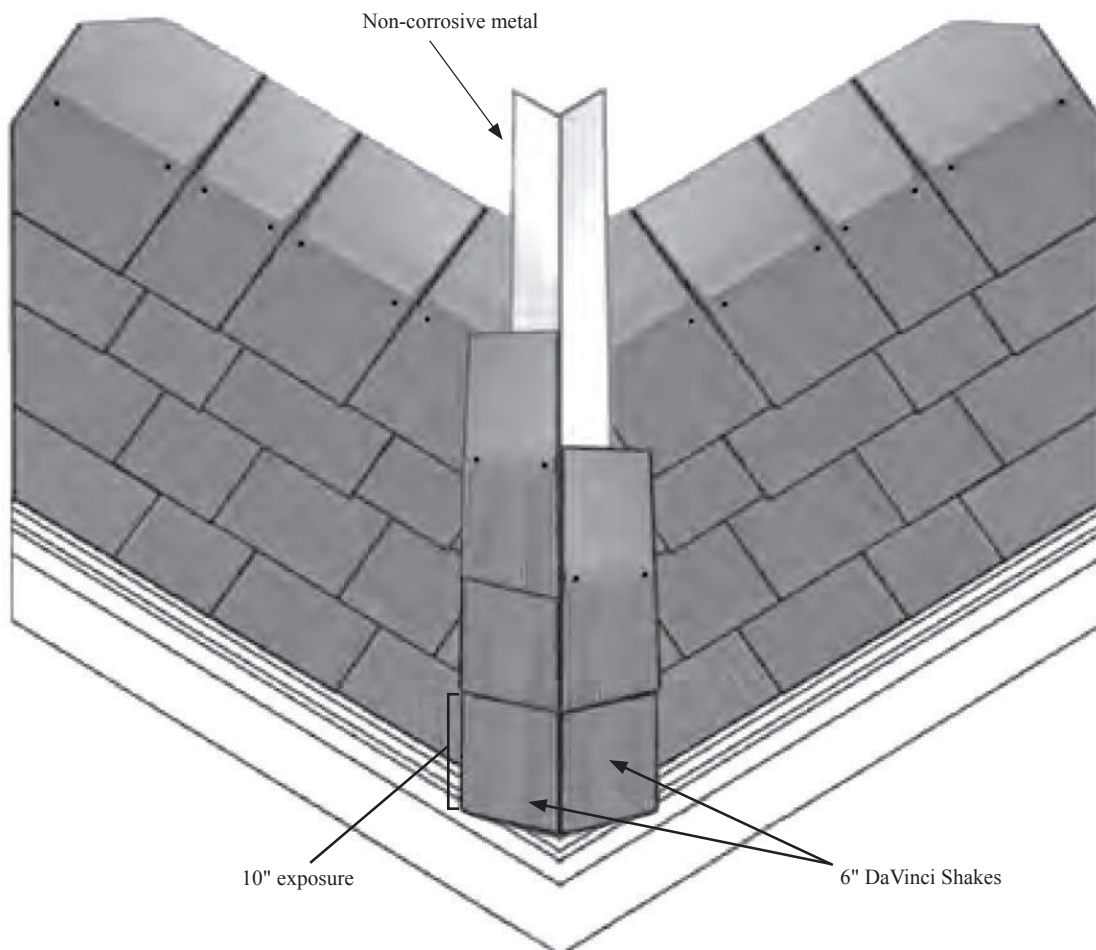

INSTALLATION

VALLEYS

Because DaVinci Shake has a rib-structure on the underside, care must be used when installing DaVinci Shake in valleys. Open or closed valley systems may be used with variants of each system. Whether installing an open or a closed valley system, valley metal should be made from 24" stock of copper, minimum .019 aluminum, or minimum 28-gauge clad steel. DaVinci requires self-adhered membrane be used in all valleys.

DaVinci Valley Metal Options

- All metal valleys to be manufactured using 2' wide panels at a minimum.
- All returns are to be 1/2"
- All Shake Diverters minimum 13/4"

Open Valley Appearance Options

Open Valley Metal, Single Open, or Closed Diverter Metal: In many cases, with steeper pitched roofs, it is acceptable to install open valley metal or either type of single diverter valley metal and cut the tile on an angle parallel and 2 1/2" from the center or center diverter. Keep in mind that the cut rib structure of the tiles may be visible from the ground with some roof pitches.

Twin Diverter Open or Closed: Double open or double closed diverter metal can be used to provide an open valley appearance while also blocking the support ribs on the underside of cut tiles. This should be made from 24" stock that is broken in the middle without diverter to look like a "V". Additionally, there should be a closed or open diverter on either side of the center line. Shake should be cut and laid against the diverters on either side to mask the rib structure. This option will leave a visible portion of metal centered on the valley commonly 5-7" wide.

Closed Valley Appearance Options

Single Open or Closed Diverter: In many cases, with steeper pitched roofs, it is acceptable to install a single open or closed diverter valley. The shake tiles are then cut appropriately in order to lay near the center diverter. This option will only leave a small seam or crown of the diverter visible and resembles a closed valley.

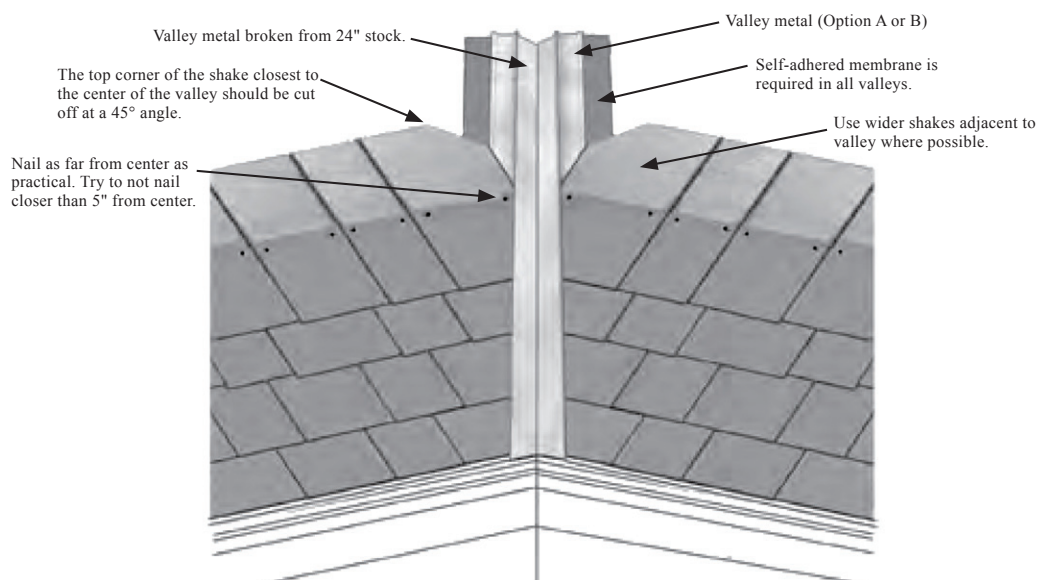
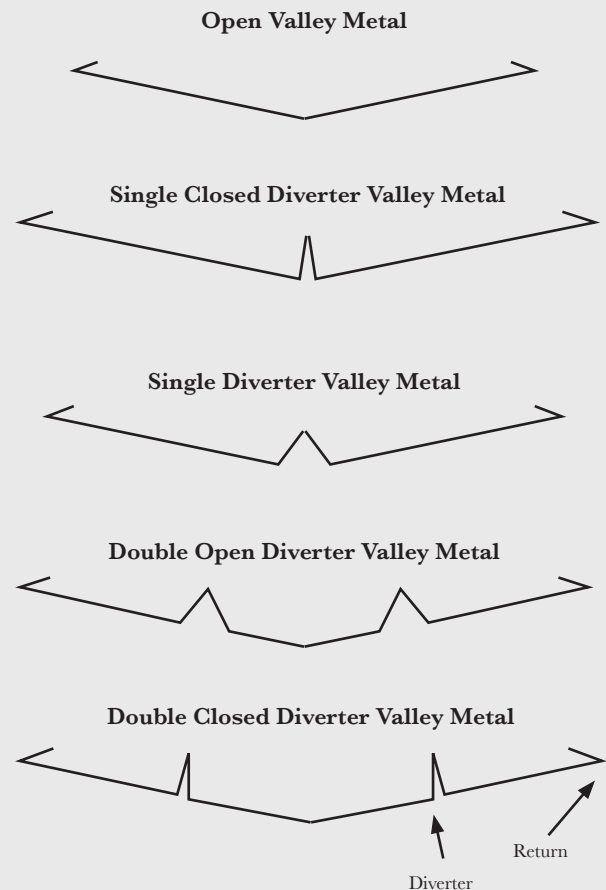

SPECIAL ISSUES

FLASHING

Flashing should be used in all areas where the roof abuts a vertical wall, dormer, chimney, skylight or other structural protrusions.

Use the step flashing method, with copper, a minimum of 28-gauge clad steel, or a minimum .019 aluminum flashing. The flashing should extend 4" up vertical walls.

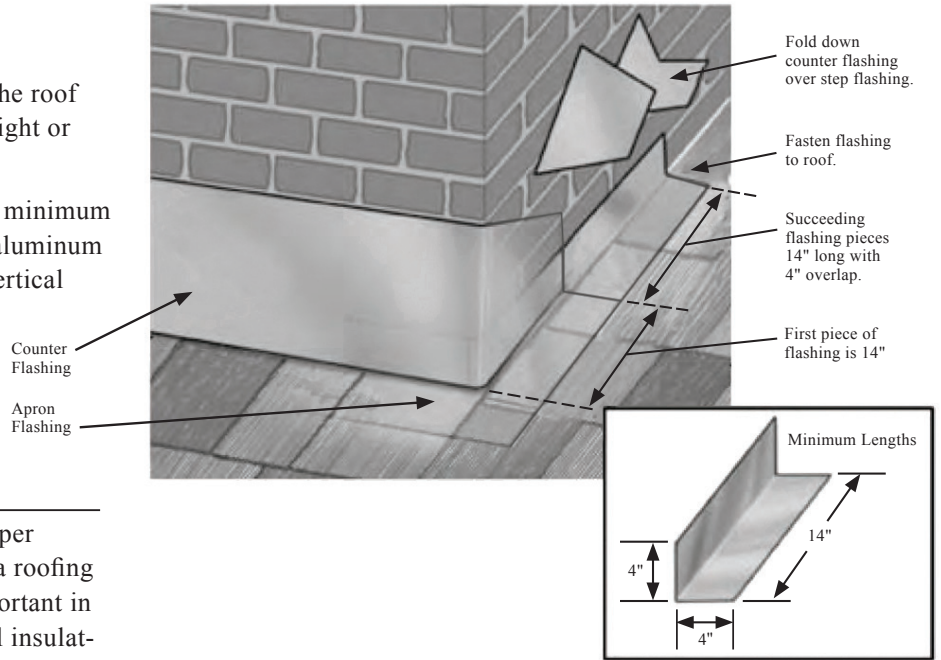

VENTILATION

In some climatic regions of the country, proper ventilation is crucial to the performance of a roofing system. Proper ventilation is especially important in cold climates where modern houses are well insulated and weather-tight. We suggest you follow standard building practices in your area and meet all national and local building codes. A continuous ridge vent combined with proper intake or eave ventilation is an especially effective ventilation system, and one that we highly recommend.

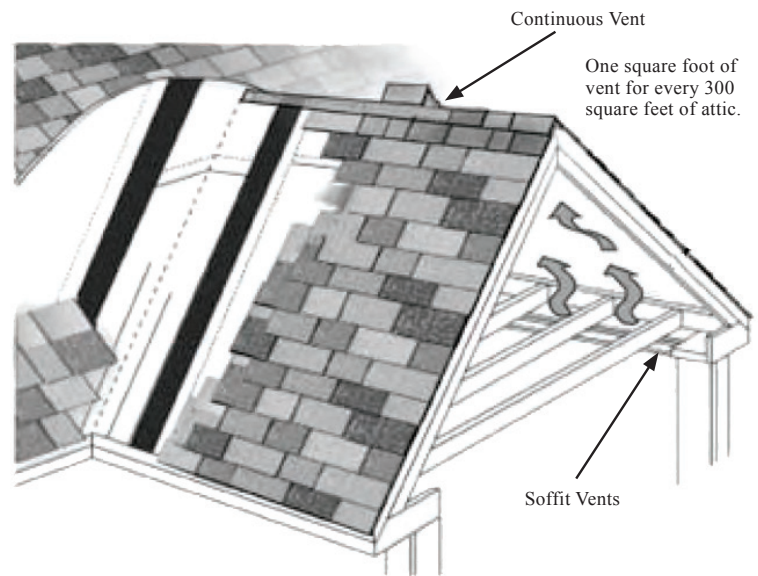

HIGH WIND AREAS

DaVinci Shake shall have a maximum 9" exposure. DaVinci Shake shall be fastened with two (2) 13/4" long ring-shank nails* below the marked holes and 9 1/2" up from the butt edge and shall penetrate through the underlying panel.

Please see "Affirmation of High Wind Roofing Installation Compliance form" for any additional installation requirements.

SNOW GUARDS

Snow guards should be considered in all geographic areas where accumulating snow fall is possible. Most kinds of brass, copper, or clad aluminum snow guard systems work well with DaVinci. Rocky Mountain Snow Guards, Inc. is good source for further information about snow guards. Contact them at www.rockymountainsnowguards.com or call 877-414-7606. It is recommended that snow guards be installed during the installation of the DaVinci roof although retro-fit snow guards are available for previously installed DaVinci roofs. Details regarding installation remain the responsibility of the installer and the customer.

For additional information please see Q & A Guide to Snow Guards at <http://dvroof.com/1BEYN1W>.

Consult with your local contractor to determine if snow guards would be appropriate for your project. DaVinci makes no representations or warranties about the propriety of snow guard installation on any given project. Rather, the decision to install snow guards rests solely with the end user.

PRODUCT FEATURES

EXPOSURE

ROOF PITCH	COURSING	INTERLAY	MAX. EXPOSURE
Less than 3:12	Not Recommended		
3:12 to 6:12	Staggered	Required*	9"
3:12 to 6:12	Straight	Required*	10"
6:12 or greater	Staggered	Optional	9"
6:12 or greater	Straight	Optional	10"

Felt interlay is recommended on any pitch. It is one of the additional underlayment options required on pitches less than 6" in 12". *If two layers of Fontana VulcaSeal is used interlay is not required.

NAILING

Each shake should be applied with two copper, non-corrosive stainless steel, or hot-dipped galvanized, 3/8" head x 1 3/4" length nails in most instances. Minimum 3/8" head is required. Roofing nails that penetrate through the roof deck and exceed it by 3/16" should be used. Shakes can be nailed by hand or with a pneumatic nail gun. Don't overdrive nails or drive nails at an angle. Keep the nail head flush with the surface of the shingle to avoid creating "craters" which can collect moisture and can also prevent the exposed end of the shingles from laying flat. Use these alignment guides with the top edge of the previous row of shakes to control the exposure.

CUTTING

DaVinci Shake can be cut with a utility knife and straight edge. Electrical circular saws (carbide blade, two teeth per inch) or cordless circular saws (a minimum of 18 volts is recommended) may also be used.

Please note: DaVinci Shake is made flat, should be stored flat and must not be installed unless it is flat and in its original form. If shakes are not stored flat and become twisted or curled, lay them flat in a warm place and they will return to their original flatness. Damaged shake should never be installed.

ELECTRO-GALVANIZED NAILS

DaVinci recommends the use of copper, stainless steel, or hot-dipped galvanized nails. We realize however that in many climatic regions nail corrosion is not a factor in the long-term performance of the roof system. Therefore DaVinci Roofscapes supports the use of Electro-galvanized nails and a system using those nails will be in compliance with the DaVinci Lifetime Limited Material Warranty. The exception to that is that if the nails fail, any portion of the warranty associated with wind performance would be void.

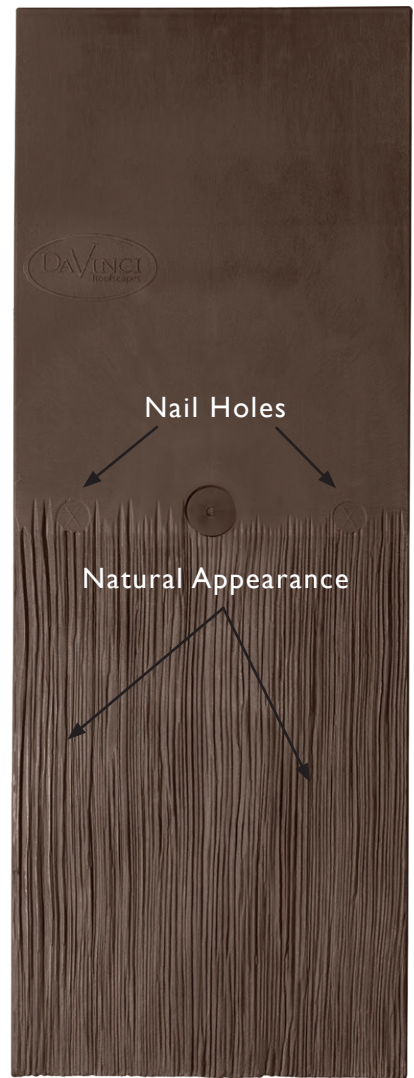

QUICK REFERENCE

- Don't overdrive or install nails at an angle
- Always leave a gap between all tiles
- Vertical, always install up the roof not one row across the roof at a time
- Install over a clean plywood deck only
- Never use red chalk
- Cut edges always go to the inside along rake edges or gable ends
- Install snowguards in any snow prone area

ISSUE	DAVINCI RECOMMENDS	ACCEPTABLE ALTERNATIVES
Valley	Copper	28-gauge clad metal
Flashing	Copper	28-gauge clad metal
Eaves Flashing	Copper	28-gauge clad metal
Nails	Non-Corrosive Stainless Steel	Hot-dipped Galvanized

For questions about DaVinci Shake or its application, contact Westlake DaVinci Roofscapes, LLC
 913-599-0766 or 800-DaVinci (800-328-4624) or www.davinciroofscapes.com
Please be sure to check DaVinci's website for updates. Installation Guide is subject to change without notice.